



A B C D E F

1

2

3

4

5

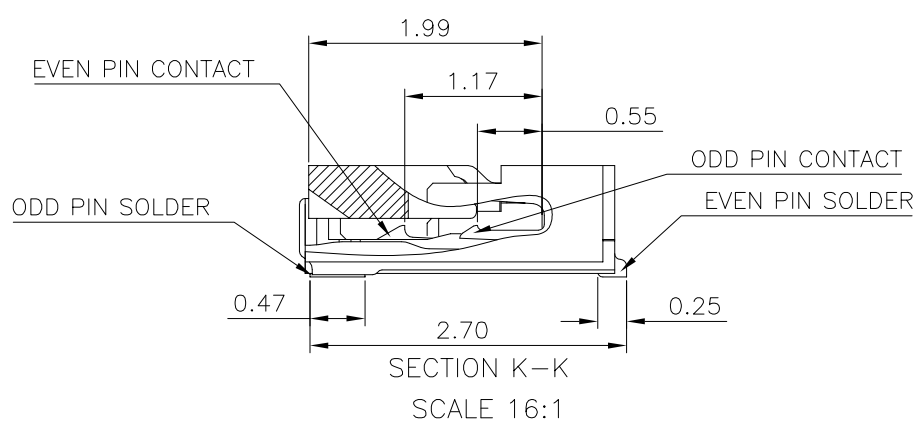
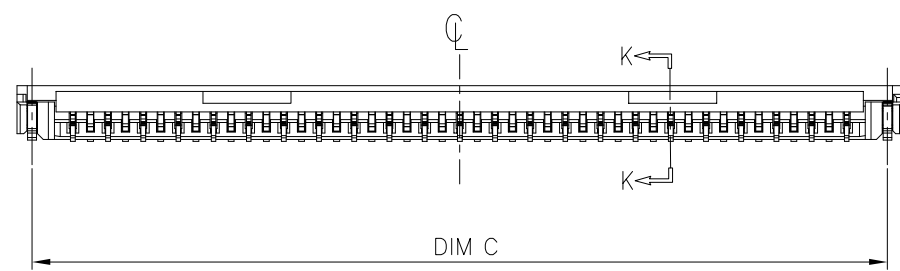
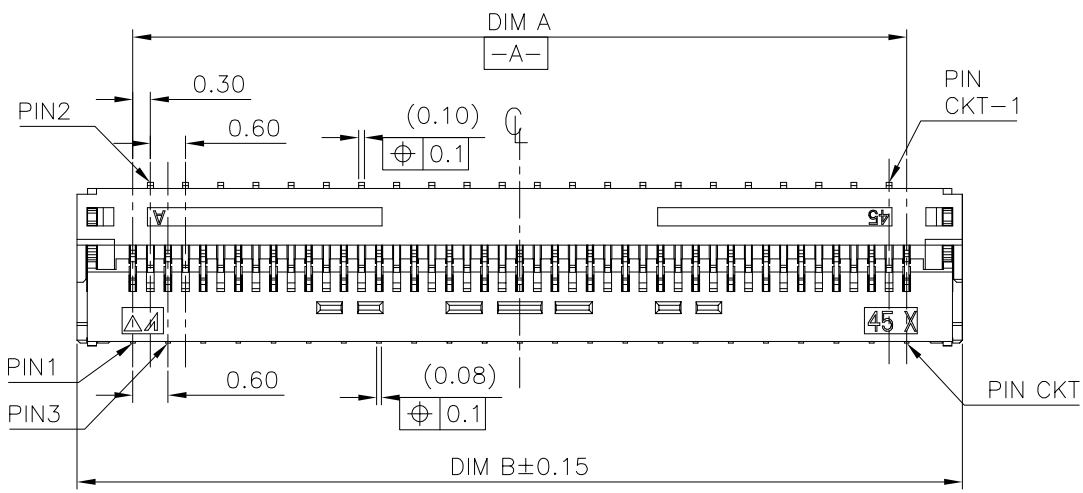

NOTES:

1. MATERIAL:
 - 1.1 HOUSING: THERMOPLASTIC, HIGH TEMP.UL94V-0, COLOR:NATURAL.
 - 1.2 ACTUATOR: THERMOPLASTIC, HIGH TEMP.UL94V-0, COLOR:BLACK.
 - 1.3 CONTACT: COPPER ALLOY
 - 1.4 FITTING NAIL: COPPER ALLOY
2. FINISH:
 - 2.1 CONTACT:
 - M: 40 MIN. NICKEL PLATING OVERALL
 - 3u" MIN. GOLD PLATING ON CONTACT
 - 1u" MIN. GOLD PLATING ON SOLDER TAILS
 - 2.2 FITTING NAIL:
 - 80u" MIN. MATT TIN PLATING ON SOLDER TAILS(LEAD FREE).
 - 40u" MIN. NICKEL UNDERPLATING OVERALL.
3. SPEC. PLS. REFER TO PS-52527-XXXX-XXX
4. PACKAGE PLS. REFER TO 52527-XXXX-XX-TRP

5. PART NUMBER 52527-XXX X X -XXX

NO OF CKT | PLATING

PACKING | M:3u" GOLD ON CONTACT AND

0:TAPE & REEL | SELECTIVENESS PLATING

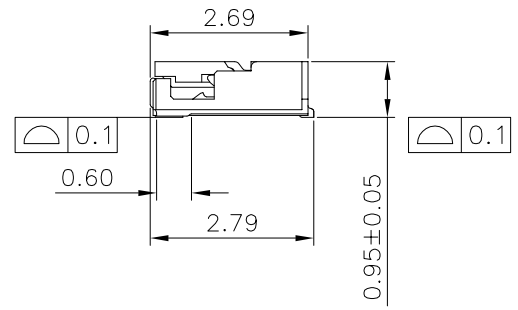

CKT	DIM A	DIM B	DIM C
11	3.00	4.90	4.39
19	5.40	7.30	6.79
45	13.20	15.10	14.59

QUALITY SYMBOLS MAJOR Ⓜ CRITICAL Ⓢ GENERAL TOLERANCES (UNLESS SPECIFIED) X. ±0.5 .X ±0.25 .XX ±0.15 .XXX ±0.1 ANGLES ±2°	DRAWN BY Wang, Kai Hung 23/05/11	DATE 23/05/11			
	CHECKED BY Liu, Yuan Huang 23/05/11	DATE 23/05/11		TITLE 0.3 MM PITCH EASY ON FPC CONN. SMT R/A B/C TYPE	
	APPROVED BY Huang Kuo Hua 23/05/11	DATE 23/05/11	UNITS mm		SIZE A4
	SCALE 8:1	SHEET NO. 1 OF 2	REV A	PART NO. SEE NOTES	

B C D E F

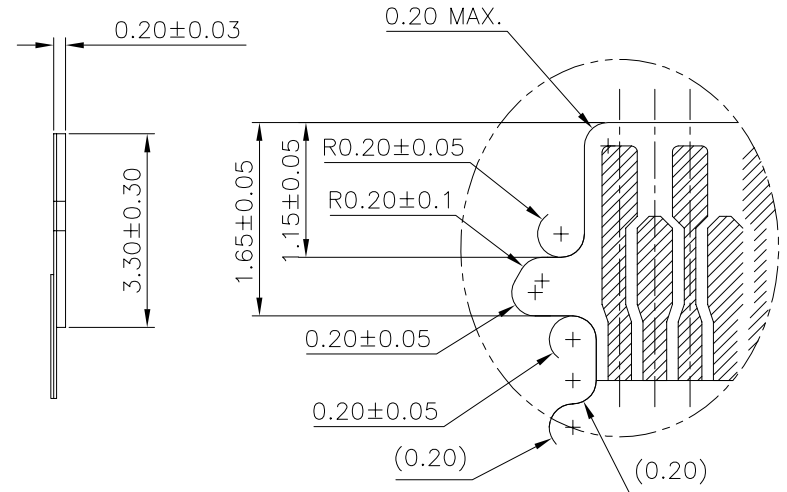
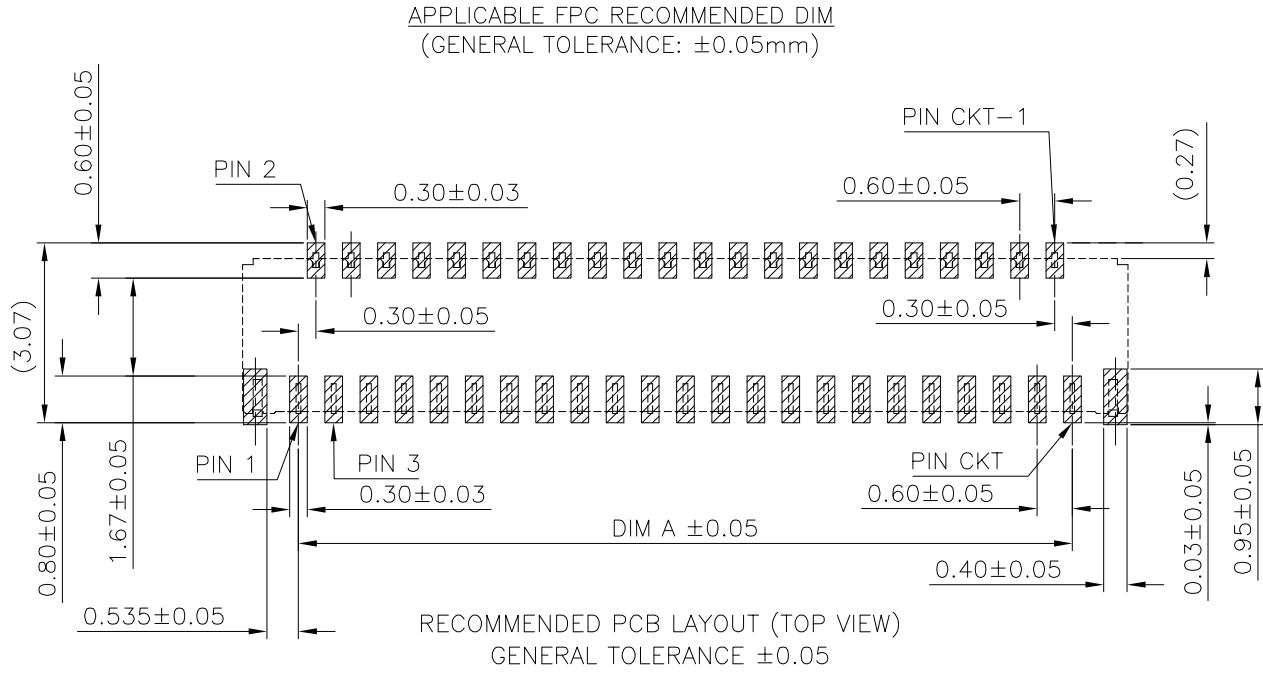
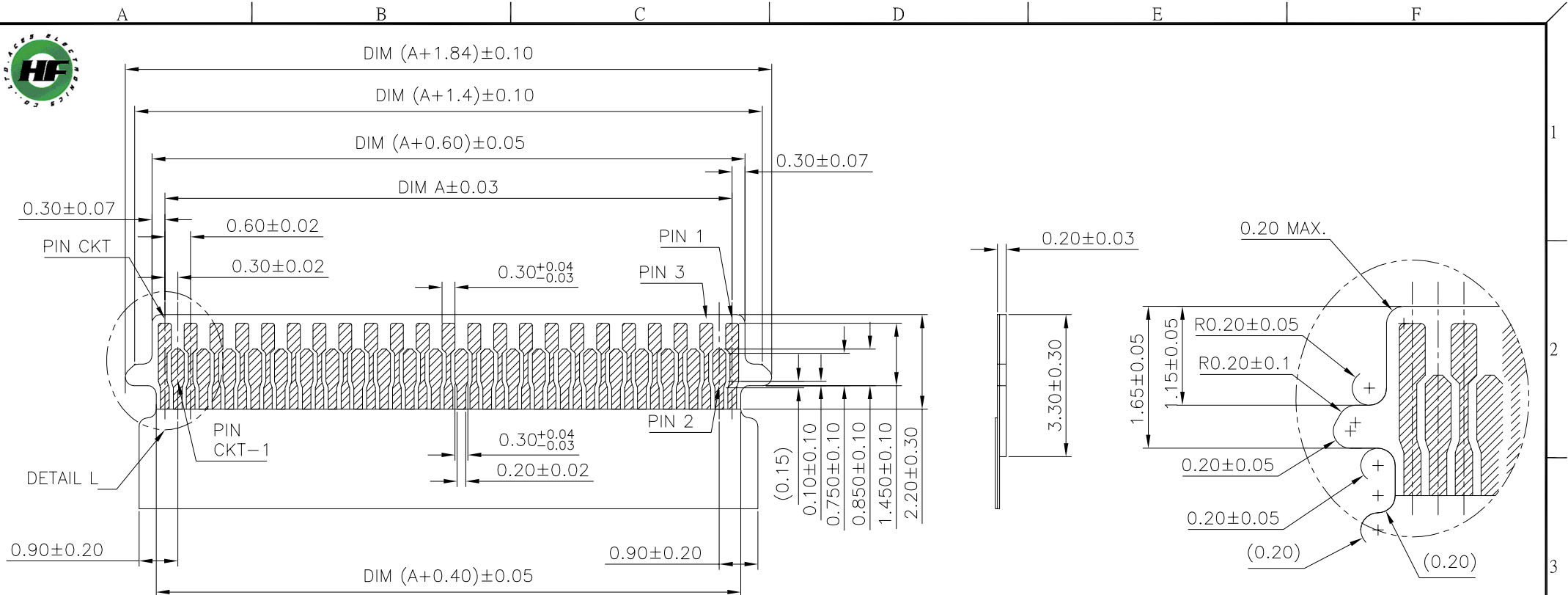

DETAIL L
SCALE 16:1

QUALITY SYMBOLS MAJOR CRITICAL GENERAL TOLERANCES (UNLESS SPECIFIED) X. ±0.5 .X ±0.25 .XX ±0.15 .XXX ±0.1 ANGLES ±2°	DRAWN BY Wang, Kai Hung 23/05/11	DATE 23/05/11	
	CHECKED BY Liu, Yuan Huang 23/05/11	DATE 23/05/11	
	APPROVED BY Huang Kuo Hua 23/05/11	DATE 23/05/11	SIZE A4
	UNITS mm		DWG NO. 52527-XXXXX-XXX
	SCALE 8:1	SHEET NO. 2 OF 2	REV A
			PART NO. SEE NOTES